



SETUP AC15RM DL



Setup AC15RM DL 230V 50Hz complete for automation of single leaf sliding gates.

Code	Leaf	Gear motors	Limit switch	Setup / Pallet
SETUP AC15RM DL	1500 Kg	AC15RM DL	Magnetic	36

MAXI 2 – Page 120



1 Transmitter
433.92 MHz -
Rolling Code

DES – Page 135



1 Key switch for
outdoor use

VISIO – Page 138



1 Pair of
photocells for
outdoor use

SUNLED 23 – Page 142



1 Flashing light
with built-in
antenna

RG1R DL



1 Control unit
with built-in
receiver

TL – Page 116



1 Sign plate

Code	Leaf	Gear motors	Limit switch	Setup / Pallet
SETUP AC15RM DL 042	1500 Kg	AC15RM DL 042	Magnetic	36

MAXI 2 – Page 120



2 Transmitters
433.92 MHz -
Rolling Code

VISIO – Page 138



1 Pair of
photocells for
outdoor use

SUNLED 23 – Page 142



1 Flashing light
with built-in
antenna

RG1R DL



1 Control unit
with built-in
receiver

TL – Page 116



1 Sign plate

Code	Leaf	Gear motors	Limit switch	Setup / Pallet
SETUP AC15RM DL EASY	1500 Kg	AC15RM DL EASY	Magnetic	36

MAXI 2 – Page 120



2 Transmitters
433.92 MHz -
Rolling Code

RG1R DL



1 Control unit
with built-in
receiver

Easy
and quick.



Digital Life Card

The innovative DL card programmes at the touch of a finger. Simplicity, coloured LEDs and reduced installation times adding value to your own time.



AC15RM DL

Irreversible electromechanical gear motor for sliding gates.
External fitting.

Code	Leaf	Motor	Description	Pcs. Pallet
AC15RM DL	1500 Kg	230V AC	Model equipped with encoder, magnetic limit switch and control unit (RG1R DL). Electronic regulation of the motor torque. Metal gear wheels.	36

Irreversible electromechanical gear motor for sliding gates. External fitting.

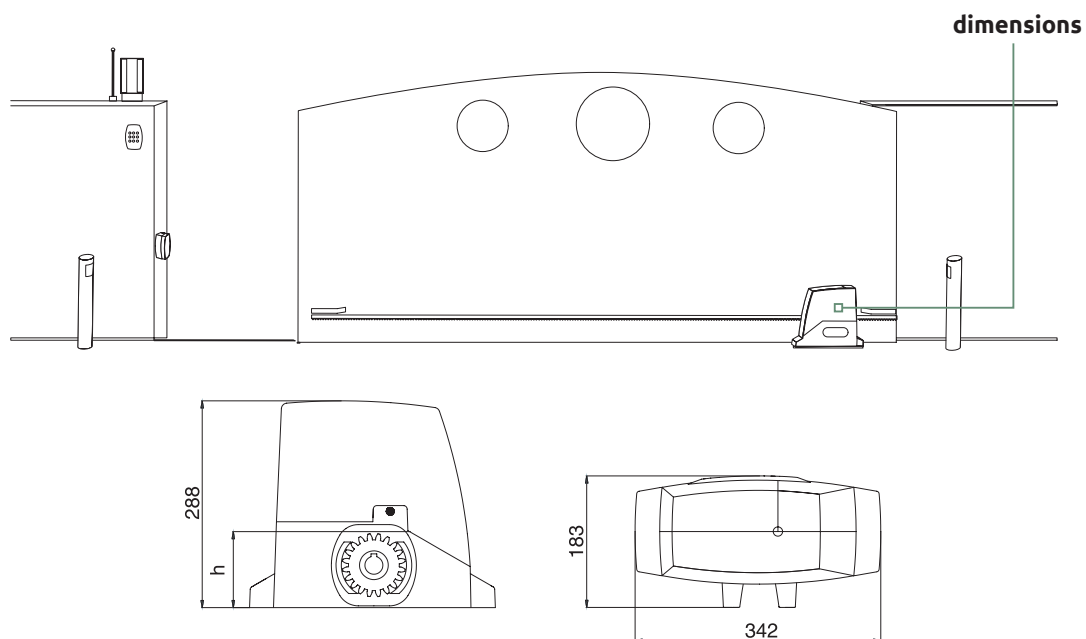

AC15RM DL

Technical specifications



	AC15RM DL
Max. gate leaf weight (Kg)	1500
Motor power supply (V)	230V AC
Power absorbed (W)	400
Thrust (N)	1500
Lubrication (Type)	Oil
Overheating protection (°C)	140
Operating T° (°C Min/Max.)	- 20 +70
Protection class (IP)	55
Speed (m/min)	8
Work intermittence (%)	50
Pinion height - h (mm)	95

AAC3



M4 Rack, 30x12x1000 galvanised and notched steel, complete with screws and spacers (4 Metres/Pack or multiple packs)

TL

- Page 116



Sign plate

