



COMUNELLO
AUTOMATION

CONDOR 220/350

Automation for swing gates
24 Vdc and 230 Vac

Life
made
easy



CONDOR 220/350

Technical features



Every single product is duly tested at the end of each assembly line

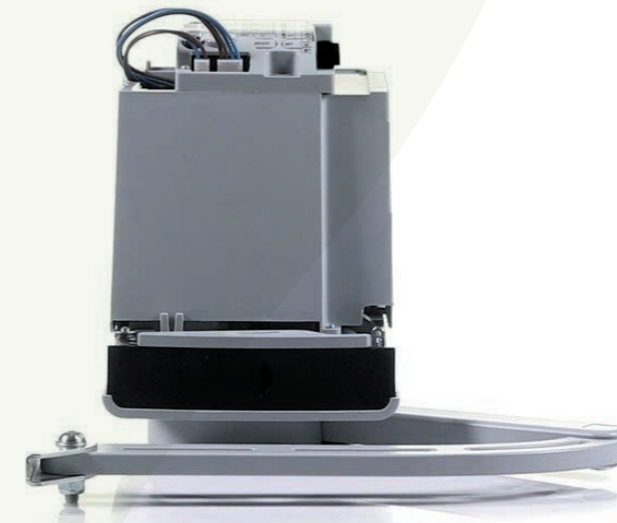

CONDOR 220

up to 2,2 m

24V

230V

CONDOR 350

up to 3,5 m

24V

DIMENSIONS (mm)

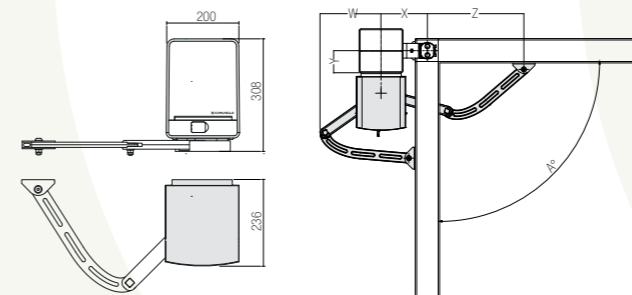

A°	X	Y	Z	W
90°	205	0	415	209
90°	190	50	415	135
90°	185	100	395	159,5
90°	170	150	372	278
110°	250	0	365	287

TECHNICAL FEATURES

	CONDOR 220 24 V	CONDOR 220 230 V	CONDOR 350 24V
Power supply	230 ~ 50 Hz		
Operator power supply	24V ONE 24V	230V ~	24V ONE 24V
Power consumption	110 W	280 W	150 W
Current input	5 A	1,2 A	6,5 A
Torque	150 Nm	250 Nm	200 Nm
Duty cycle	Intensive use	30%	Intensive use
Protection rating	IP 44		
Insulation class	2 earth	1 earth	2
Working temperature	-20°C / +50°C		
Speed	0,10 rad/s		
Weight	10 Kg	10 Kg	10 Kg

OPERATING LIMITS CONDOR 220

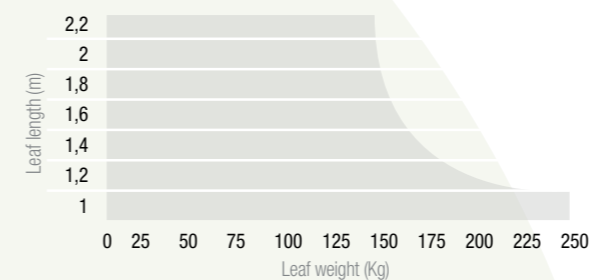

OPERATING LIMITS CONDOR 350



OFFICIAL DEALER:



AUTOMATION FOR GATES, DOORS AND BARRIERS

FRATELLI COMUNELLO S.P.A.

HEADQUARTERS

Via Zarpellon, 33
36027 San Giuseppe di Cassola, Vicenza, Italy
Tel. +39 0424 585111 Fax +39 0424 533417
info@comunello.it www.comunello.com

REGISTERED OFFICE

Via Cassola,64 - C.P.79
36027 Rosà, Vicenza, Italy
Tel. +39 0424 585111 Fax +39 0424 533417
info@comunello.it www.comunello.com

CONDOR Accessories



		AC-101	Articulated arm for Condor 220/350, L=408 mm + 350mm	GCR004BAN0G00	1 2,9 kg
		AC-108	Slide arm for Condor 220/350, L=652,5 mm	GCR008BAN0B00	1 5,1 kg
		AC-110	Key operated emergency release	GCR001SCN0G00	1 1,2 kg
		AC-100	Ambidextrous articulated arm for Condor 500, L=408 mm + 350mm	GCR001BAN0G00	1 2,9 kg
		AC-102	Locking arm for Condor 500/500S, L=385 mm + 330mm	GCR001BAN0B00	1 3,2 kg
		AC-103	Locking arm for Condor 500/500S - L=503 mm + 430mm	GCR002BAN0B00	1 3,7 kg
		AC-104	Locking arm for Condor 500/500S - L=238 mm + 620mm	GCR003BAN0B00	1 4,1 kg
		AC-110	Key operated emergency release	GCR001SCN0G00	1 1,2 kg

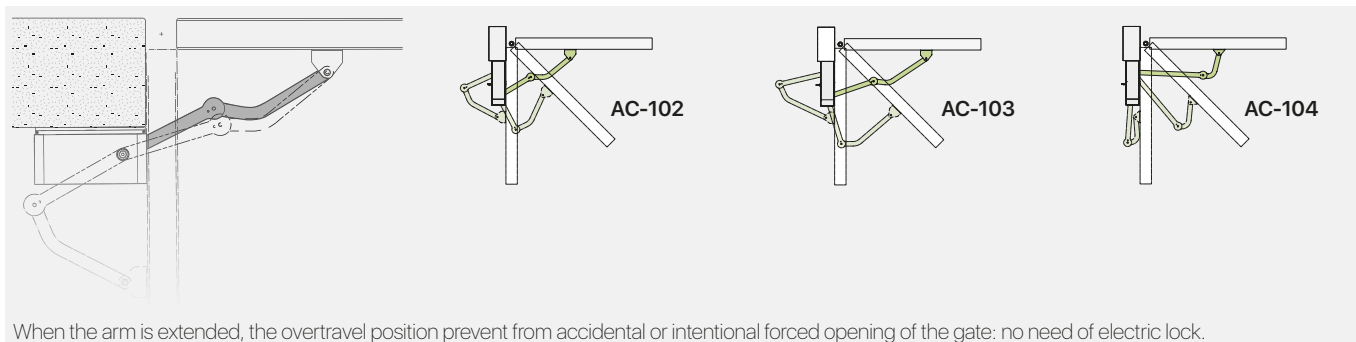

When the arm is extended, the overtravel position prevent from accidental or intentional forced opening of the gate: no need of electric lock.

CONDOR KIT System



24V Complete kits with articulated arm actuators for swinging gates, 24 Vdc, up to 5 m length

	KIT System						
 Condor 220	ENTRY	GKCR220LLB930	•	•	CU 24V HP	19,2 kg	16
	LIGHT	GKCR220LLB920	•	•	CU 24V HP	19,4 kg	16
	FULL	GKCR220LLB903	•	•	CU 24V HP	19,6 kg	16
 Condor 350	ENTRY	GKCR350LLB930	•	•	CU 24V HP	19,2 kg	16
	LIGHT	GKCR350LLB920	•	•	CU 24V HP	19,4 kg	16
	FULL	GKCR350ELB903	•	•	CU 24V HP	19,6 kg	16
 Condor 500*	ENTRY	GKCR500LLB930	•	•	QUAD 24V HP	26,0 kg	8
	LIGHT	GKCR500LLB920	•	•	QUAD 24V HP	26,2 kg	8
	FULL	GKCR500LLB903	•	•	QUAD 24V HP	26,4 kg	8
 Condor 500S	ENTRY	GKCR050SEL930	•	•	CU 24V HP	18,1 kg	10
	LIGHT	GKCR050SEL920	•	•	CU 24V HP	18,3 kg	10
	FULL	GKCR050SEL900	•	•	CU 24V HP	18,5kg	10

= Mechanical endstops - = Electronical endstops - = Encoder

*Condor 500 Accessories included 2 ambidextrous articulated arm AC-100 :





CONDOR KIT System



230V Complete kits with articulated arm actuators for swinging gates, 230 Vac, up to 5 m length

		KIT System							
 Condor 220	ENTRY		GKCR220LHB930	•	•	CU 230V HP	19,2 kg	16	
	LIGHT		GKCR220LHB900	•	•	CU 230V HP	19,4 kg	16	
	FULL		GKCR220LHB903	•	•	CU 230V HP	19,6 kg	16	
 Condor 500	ENTRY		GKCR500LHB930	•	•	QUAD 230V HP	25,8 kg	8	
	LIGHT		GKCR500LHB920	•	•	QUAD 230V HP	26 kg	8	
	FULL		GKCR500EHB903	•	•	QUAD 230V HP	26,2 kg	8	
 Condor 500S	ENTRY		GKCR050SEH930	•	•	CU 230V HP	23 kg	10	
	LIGHT		GKCR050SEH920	•	•	CU 230V HP	23 kg	10	
	FULL		GKCR050SEH900	•	•	CU 230V HP	23 kg	10	

 = Mechanical endstops -  = Electronical endstops -  = Encoder