

CONDOR 500

Automation for swing gates
24 Vdc and 230 Vac

Life
made
easy



CONDOR 500

Technical features



Actuator support bracket in galvanized steel included



Integrated electromechanical limit switches



Every single product is duly tested at the end of each assembly line

DIMENSIONS (mm)

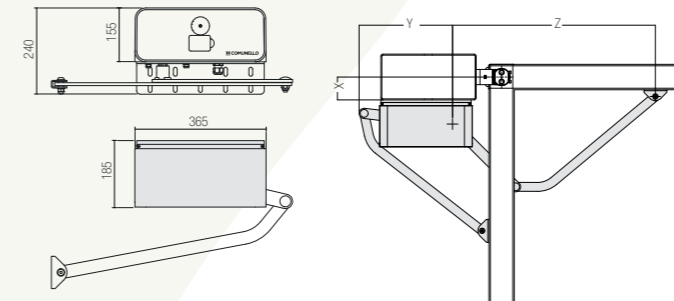

X	Z	Y
50	554	535
100	555	635
150	555	535
200	555	690

OPERATING LIMITS CONDOR 500

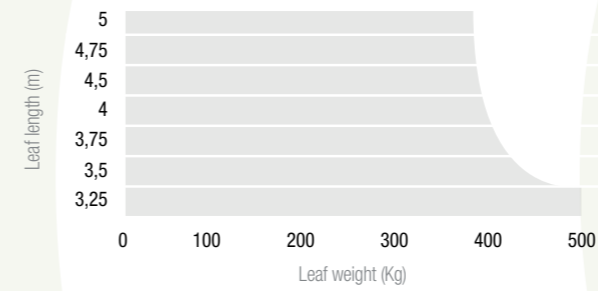

AC-102-103-104

Ambidextrous arms in painted steel with locking system

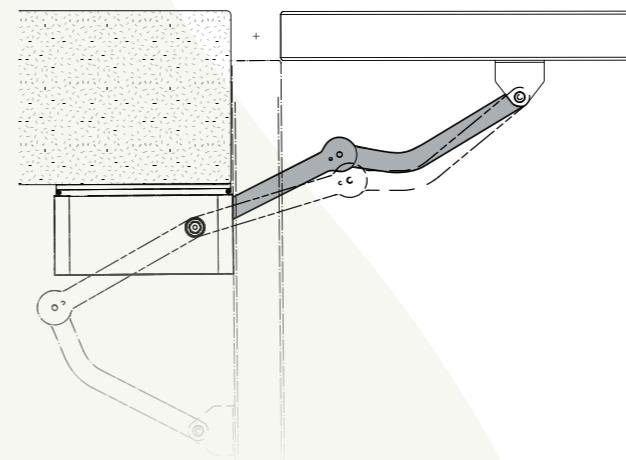

Technical features

	CONDOR 500 24V	CONDOR 500 230V
Voltage	24 VDC	230 VAC 50 Hz
Power consumption	150 W	280 W
Max. absorption	6,5 A	1,2 A
Max. thrust	330 Nm	440 Nm
Duty cycle	Intensive use	50%
Protection degree (IP)	IP44	IP44
Insulation class	2	1 (earthing)
Working temperature	-20°C / +50°C	-20°C / +50°C
No-load speed	0,15 rad/sec	0,1 rad/sec
Weight	12 kg	12 kg



CONDOR 500 24V 230V
up to 5 m



L = 385mm + 330mm



L = 503mm + 430mm



L = 238mm + 620mm

OFFICIAL DEALER:



AUTOMATION FOR GATES, DOORS AND BARRIERS

FRATELLI COMUNELLO S.P.A.

HEADQUARTERS

Via Zarpellon, 33
36027 San Giuseppe di Cassola, Vicenza, Italy
Tel. +39 0424 585111 Fax +39 0424 533417
info@comunello.it www.comunello.com

REGISTERED OFFICE

Via Cassola,64 - C.P.79
36027 Rosà, Vicenza, Italy
Tel. +39 0424 585111 Fax +39 0424 533417
info@comunello.it www.comunello.com

CONDOR KIT System



24V Complete kits with articulated arm actuators for swinging gates, 24 Vdc, up to 5 m length

	KIT System						
 Condor 220	ENTRY	GKCR220LLB930	•	•	CU 24V HP	19,2 kg	16
	LIGHT	GKCR220LLB920	•	•	CU 24V HP	19,4 kg	16
	FULL	GKCR220LLB903	•	•	CU 24V HP	19,6 kg	16
 Condor 350	ENTRY	GKCR350LLB930	•	•	CU 24V HP	19,2 kg	16
	LIGHT	GKCR350LLB920	•	•	CU 24V HP	19,4 kg	16
	FULL	GKCR350ELB903	•	•	CU 24V HP	19,6 kg	16
 Condor 500*	ENTRY	GKCR500LLB930	•	•	QUAD 24V HP	26,0 kg	8
	LIGHT	GKCR500LLB920	•	•	QUAD 24V HP	26,2 kg	8
	FULL	GKCR500LLB903	•	•	QUAD 24V HP	26,4 kg	8
 Condor 500S	ENTRY	GKCR050SEL930	•	•	CU 24V HP	18,1 kg	10
	LIGHT	GKCR050SEL920	•	•	CU 24V HP	18,3 kg	10
	FULL	GKCR050SEL900	•	•	CU 24V HP	18,5kg	10

= Mechanical endstops - = Electrical endstops - = Encoder

*Condor 500 Accessories included 2 ambidextrous articulated arm AC-100 :



CONDOR KIT System



230V Complete kits with articulated arm actuators for swinging gates, 230 Vac, up to 5 m length

	KIT System						
	ENTRY	GKCR220LHB930	•	•	CU 230V HP	19,2 kg	16
	LIGHT	GKCR220LHB900	•	•	CU 230V HP	19,4 kg	16
	FULL	GKCR220LHB903	•	•	CU 230V HP	19,6 kg	16
	ENTRY	GKCR500LHB930	•	•	QUAD 230V HP	25,8 kg	8
	LIGHT	GKCR500LHB920	•	•	QUAD 230V HP	26 kg	8
	FULL	GKCR500EHB903	•	•	QUAD 230V HP	26,2 kg	8
	ENTRY	GKCR050SEH930	•	•	CU 230V HP	23 kg	10
	LIGHT	GKCR050SEH920	•	•	CU 230V HP	23 kg	10
	FULL	GKCR050SEH900	•	•	CU 230V HP	23 kg	10

= Mechanical endstops - = Electronical endstops - = Encoder