

Life
made
easy

EAGLE

UNDERGROUND ACTUATOR
230V AND 24V VERSIONS



EAGLE NEW 2021

Underground electromechanical actuators for residential swing gates. For leaves up to 3.5 m.



EAGLE: ACCURATE SILENT AND RELIABLE

Gear lubrication with arctic grease

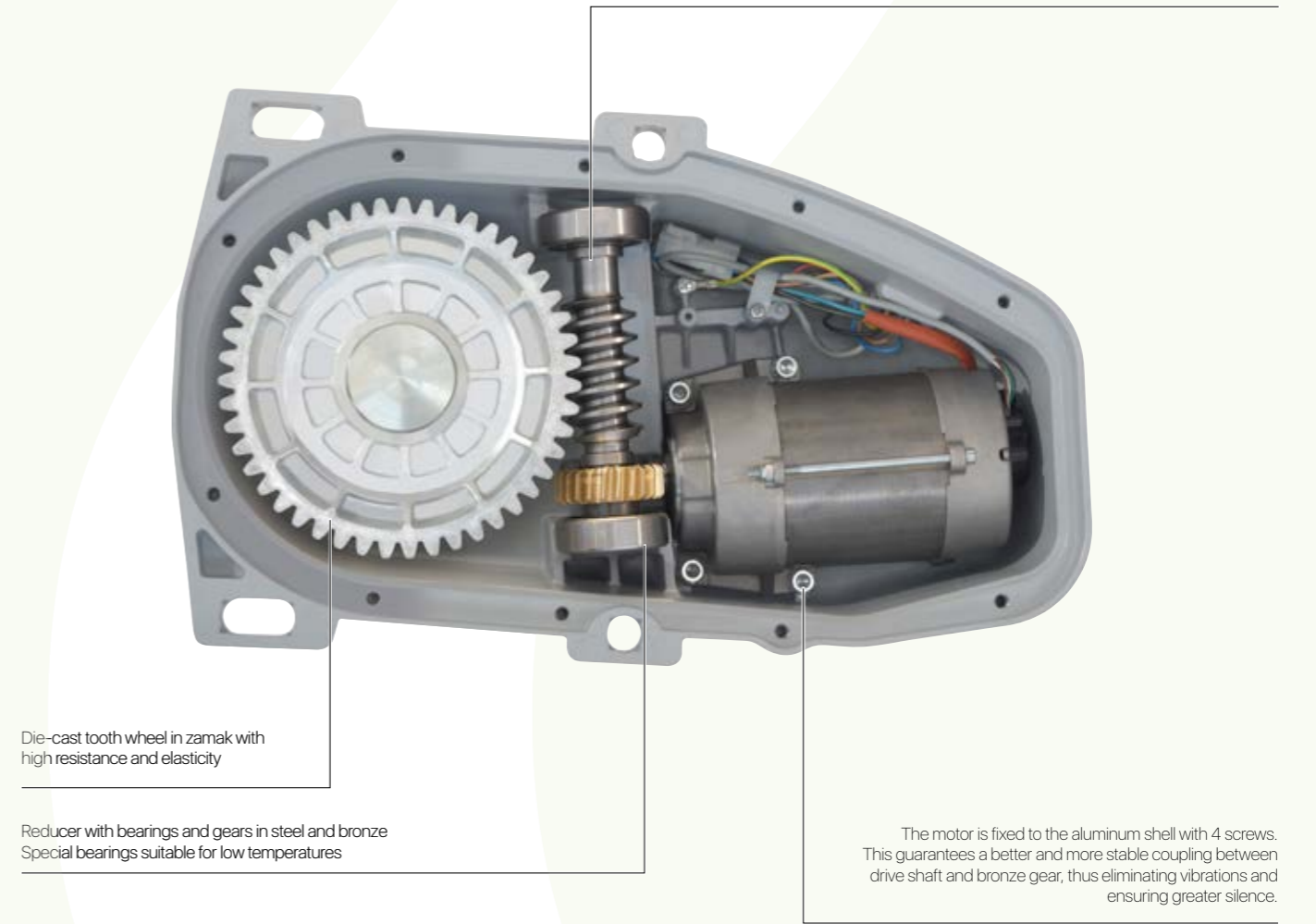

LEVERAGE INCLUDED



COMPATIBLE ACCESSORIES

AC-185
180° opening kit



AC-190
External limit switches kit



AC-160
Unlocking system with cylinder key



AC-170
Unlocking system without cylinder



TECHNICAL FEATURES

	EAGLE 350 - ONE	EAGLE 350	ENCODER EAGLE 350	EAGLE 350	ENCODER EAGLE 350
Operating power supply	24V	24V	24V	230V ~ 50Hz	230V ~ 50Hz
Power consumption	150 W	150 W	150 W	280 W	280 W
Absorption	6.5 A	6.5 A	6.5 A	1.2 A	1.2 A
Maximum torque	220 Nm	220 Nm	220 Nm	300 Nm	300 Nm
Duty cycle	Intensive use	Intensive use	Intensive use	50,00%	50,00%
Protection rating	IP67	IP67	IP67	IP67	IP67
Insulation class	3 (selv)	3 (selv)	3 (selv)	1 (earthing)	1 (earthing)
Operating temp.	from -20°C to +50°C	from -20°C to +50°C	from -20°C to +50°C	from -20°C to +50°C	from -20°C to +50°C
Minimum time of opening to 90° (without slowdowns)	~ 12 sec (adjustable)	~ 12 sec (adjustable)	~ 12 sec (adjustable)	~ 19 sec	~ 19 sec
Motor mass	11.3 Kg	11.3 Kg	11.3 Kg	11.6 Kg	11.6 Kg



Every single product is regularly tested at the end of the assembly line

MAIN FEATURES

Performance: Mechanical performance and lubrication tested and guaranteed even at low temperatures

Speed: Nominal speed and adjustable slowdown

Obstacle detection: Obstacle detection by current absorption or by encoder

Protection: IP67 Degree of protection tested and guaranteed thanks to the particularly effective gasket between the 2 bases. Stainless steel screws.

LIMITS OF USE



DIMENSIONS (mm)

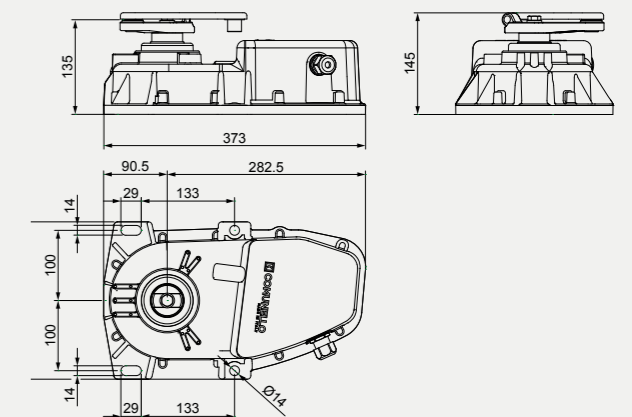

EAGLE BOX

Foundation box for EAGLE underground actuator



Rubber caps to protect the fixing screws

The plugged holes simplify the passage of cables and drain pipes



EAGLE BOX

Black cataphoresis with galvanized cover



EAGLE BOX-INOX

Stainless steel



EAGLE BOX-HG

Hot-dip galvanized foundation box for greater corrosion resistance. A minimum thickness of 60 microns is guaranteed as required by the UNI EN ISO 1461 standard. Cover in AISI 316L stainless steel

DIMENSIONS (mm)

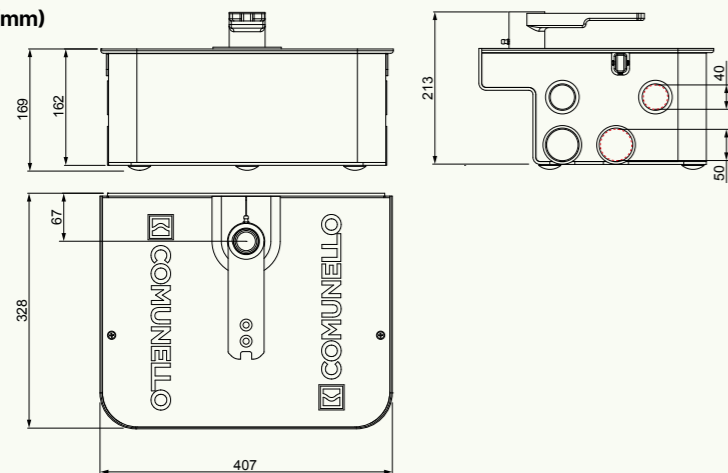

INCLUDED ACCESSORIES



AC-160 AC-170 NEW 2021

The new built-in lever device makes manual release simple and easy to activate.



Ergonomics, practicality and small footprint: always available handle integrated in the release device.

Strength and quality guaranteed by die-cast aluminum base and lever. Available in the version with and without key. Also compatible with previous versions of EAGLE actuator



The shape and size of the handle ensure easy manual release.



AC-160

Manual release with cylinder and key



AC-170

Manual release without cylinder



OFFICIAL DEALER:

 **COMUNELLO**
AUTOMATION

AUTOMATION FOR GATES, DOORS AND BARRIERS

FRATELLI COMUNELLO S.P.A.

HEADQUARTERS

Via Zarpellon, 33

36027 San Giuseppe di Cassola, Vicenza, Italy

Tel. +39 0424 585111 Fax +39 0424 533417

info@comunello.it www.comunello.com

REGISTERED OFFICE

Via Cassola,64 - C.P.79

36027 Rosà, Vicenza, Italy

Tel. +39 0424 585111 Fax +39 0424 533417

info@comunello.it www.comunello.com

EAGLE

Automation for swinging gates
24 Vdc and 230 Vac



24 Vdc and 230 Vac underground actuators for swinging gates up to 3,5 m length

Eagle 350	24 Vdc	GEE03500L1G00A		•	13,2 kg	60
Eagle 350	24 Vdc	GEE0350EL1G00A	•	•	12,7 kg	60
Eagle 350	230 Vac	GEE03500H1G00A		•	13,5 kg	60
Eagle 350	230 Vac	GEE0350EH1G00A	•	•	13,4 kg	60

Accessories included:



Versions with 10 m cable included



KIT System

ENTRY KIT



2 Motors EAGLE
10 m cable with
Encoder

Control Unit

Victor 2Ch RC

Tab AC-40

LIGHT KIT

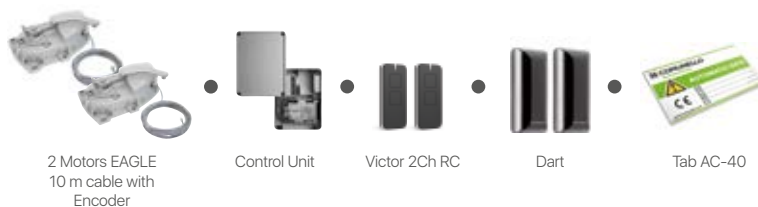

2 Motors EAGLE
10 m cable with
Encoder

Control Unit

Victor 2Ch RC

Dart

Tab AC-40

FULL KIT



2 Motors EAGLE
10 m cable with
Encoder

Control Unit

Victor 2Ch RC

Dart











Swift Y 24V

Tab AC-40

EAGLE KIT System





24V Complete kits with underground actuators for swinging gates, 24 Vdc, up to 3.5 m leaf

		KIT System					
		ENTRY 	GKEE035EL0930A	QUAD 24V-HP	•	28 kg	12
		LIGHT 	GKEE035EL0920A	QUAD 24V-HP	•	28 kg	12
		FULL 	GKEE035EL0900A	QUAD 24V-HP	•	28 kg	12

Versions with 10 m cable included

230V Complete kits with underground actuators for swinging gates, 230 Vac, up to 3.5 m leaf

		KIT System					
		ENTRY 	GKEE035EH0930A	QUAD 230V-HP	•	29,6 kg	12
		LIGHT 	GKEE035EH0920A	QUAD 230V-HP	•	29,6 kg	12
		FULL 	GKEE035EH0900A	QUAD 230V-HP	•	29,6 kg	12

Versions with 10 m cable included

EAGLE BOX



EAGLE BOX

Black cataphoresis foundation box with galvanised lid

GEE000BXN0B00

1

10,8 kg

	<p>EAGLE BOX-HG with 316L</p>	<p>Hot dipped galvanised foundation box with 316L stainless steel lid</p>	<p>GEE000BXN0G00</p>	<p>1</p>	<p>10,8 kg</p>
--	--------------------------------------	---	----------------------	----------	----------------



EAGLE BOX-INOX

Stainless steel foundation box

GEE000BXNIS00

1

11,5 kg

EAGLE Accessories



AC-160

Unlocking system with lever and key

GEE002SBN0G00A

1,20 kg

1,20 kg



AC-170

Unlocking system with lever

GEE003SBN0G00A

1,10 kg

1,10 kg



AC-185

180° opening set

GEE360ASN0G01A

1

3,8 kg



AC-190

External limit switches set

GEE001FIN0B00A

1

0,2 kg